

## 5 SERIES - 1/6 HP

### APPLICATIONS

Commercial, industrial, and home uses where water must be transferred or recirculated

### FEATURES

- 1/6 hp shaded pole motor with overload protection
- Designed for continuous duty
- Pumps down to 1/8" (3.2 mm)
- 1" FNPT (25.4 mm) discharge (includes garden hose adapter)
- Removable inlet screen for easy cleaning
- Multiple switch options for automatic operation
- Multiple power cord lengths available
- 120 °F (49 °C) liquid temperature rating
- cCSAus on models 505300, 505350, 505400, 505486, 505000, 505025, and 505176



### SERIES SPECIFICATIONS

Volts	Hz	Amps		Watts	Performance (GPH @ Height in Feet)					Shut-Off (ft)	PSI
		FLA	Start		1'	3'	5'	10'	20'		
115	60	5	6.4	380	1200	1170	1100	1000	520	26.3'	11.4
230	60	2.5	3.2	380	1200	1170	1100	1000	520	26.3'	11.4

Item No.	Model	HP	Volts	Switch Type/ Operation	On Level	Off Level	Cord	Weight
505300	5-ASP	1/6	115	Piggyback Diaphragm	6" - 9" 15.2 cm - 23 cm	1" - 4" 2.5 cm - 10 cm	10' 3 m	9 lbs 4.08 Kg
505350	5-ASP-LL	1/6	115	Piggyback Diaphragm	2" - 3" 5 cm - 7.6 cm	0.5" - 1.5" 1.27 cm - 3.8 cm	18' 5.5 m	10.25 lbs 4.65 Kg
505400	5-ASP-FS	1/6	115	Integral Float Switch	10" - 12" 24.5 cm - 30.5 cm	2" - 4" 5.1 cm - 10.2 cm	10' 3 m	9 lbs 4.08 Kg
505486	5-MSPR (black pump)	1/6	115	Manual	-	-	10' 3 m	9 lbs 4.08 Kg
505000	5-MSP	1/6	115	Manual	-	-	10' 3 m	8.25 lbs 3.74 Kg
505500	5-MSP	1/6	127	Manual	-	-	10' 3 m	8.25 lbs 3.74 Kg
505025	5-MSP	1/6	115	Manual	-	-	25' 7.6 m	8.75 lbs 3.97 Kg
505176	5-MSP	1/6	115	Manual	-	-	18' 5.5 m	8.75 lbs 3.97 Kg
505202	5-MSP	1/6	230	Manual	-	-	12' 3.6 m (w/o plug)	8.25 lbs 3.74 Kg

# UTILITY PUMPS

## 5 SERIES - 1/6 HP

### ENGINEERING DATA

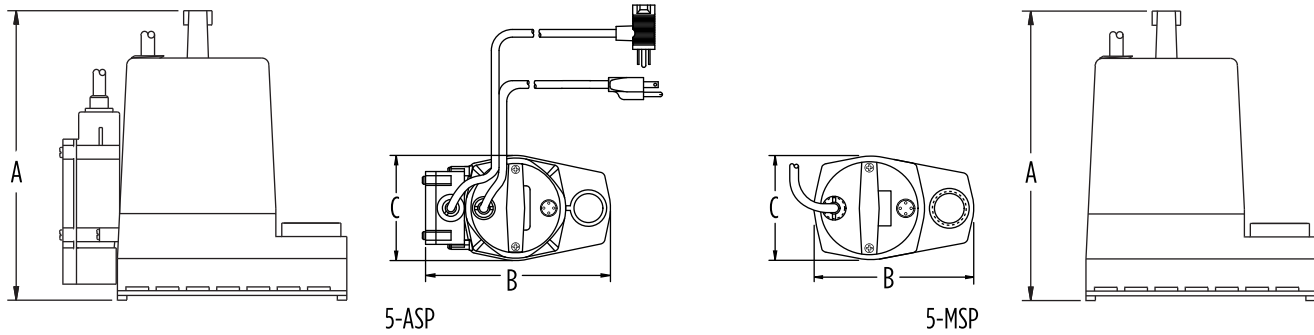

Model	A	B	C
5-MSP	7.78" 19.76 cm	6.1" 15.49 cm	4.13" 10.49 cm
5-ASP	7.78" 19.76 cm	7.75" 19.69 cm	4.13" 10.49 cm

### PERFORMANCE DATA

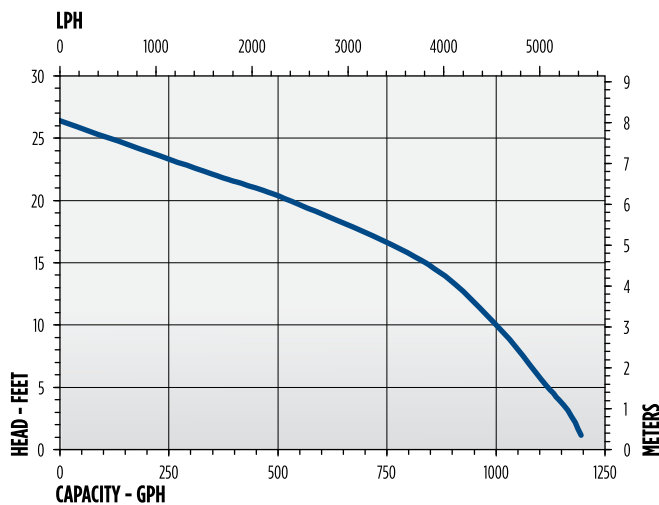

### CONSTRUCTION

<b>Motor Housing</b>	Epoxy-coated cast aluminum
<b>Impeller Material</b>	Nylon
<b>Impeller Type</b>	Semi-open
<b>Volute</b>	Nylon
<b>Motor Shaft</b>	Stainless steel
<b>Shaft Seal</b>	Fluoroelastomer (FKM)
<b>Fasteners</b>	Stainless steel
<b>Bearings</b>	Bronze sleeve
<b>Power Cord</b>	SJTW