



42371 Avenida Alvarado
Temecula, CA 92590
TOLL FREE (800) 454-2725
TEL (951) 296-3480
FAX (951) 296-3490
www.aquauv.com

Aqua Ultraviolet

Ultima II Filter Instruction Manual

(For Units Up To 30,000 Gallons)



SEE INSIDE FOR COMPLETE LINE OF FILTERS

Ultima II Filters 1000 - 30000 Gallon Units

Ultima II 1000

12" Dia. x 22" Tall - 1 1/2"

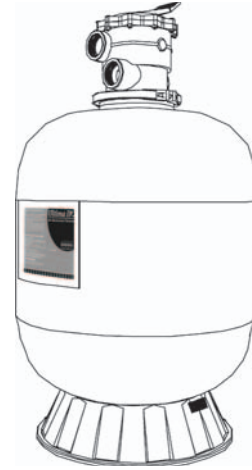
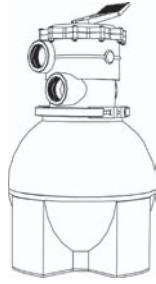

Ultima II 10000

24 1/2" Dia. x 42" Tall

Ultima II 2000

16 1/2" Dia. x 33" Tall

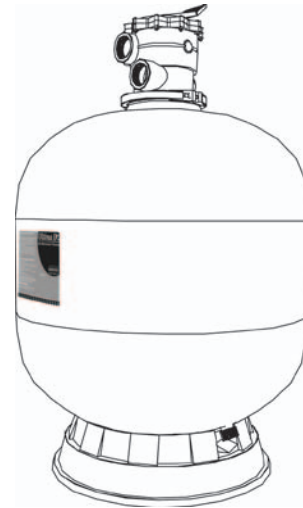

Ultima II 20000

30 1/2" Dia. x 48" Tall

Ultima II 4000

20 1/2" Dia. x 35" Tall

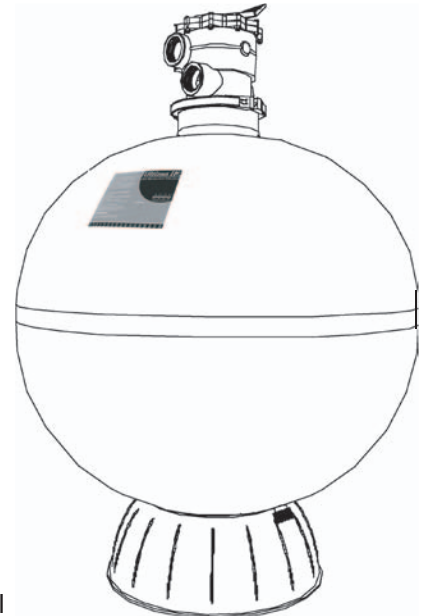

Ultima II 6000

22 1/2" Dia. x 41" Tall

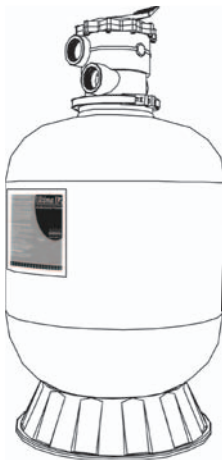

Ultima II 30000

37 1/2" Dia. x 54 1/2" Tall

TABLE of CONTENTS

Important Information..... 1
Warranty..... 1-2
Introduction..... 3
How Ultraviolet Works..... 3
Sizing Chart..... 3
Frequently Asked Questions..... 4
Parts List..... 5
Recommended Pond and Aquarium Layout..... 6
Installation Instructions..... 7
Valve Settings..... 10
Maintenance..... 11
Trouble Shooting Guide..... 15
Incorrect Installations..... 16

THIS SECTION CAN BE USED FOR NOTES:

IMPORTANT INFORMATION



THANK YOU FOR PURCHASING THE BEST FILTRATION SYSTEM

WE CAN HELP YOU

Returning the product is expensive and time consuming for you, your retailer and for us, the manufacturer. Should you encounter any problems with your product, please call our toll free "HELP" line for assistance. **PLEASE DO NOT** return your product to the store! Your dealer or distributor cannot offer any warranty work or exchanges on your product.



**In the US please call
TOLL FREE 1 - 800 - 454 - 2725
(951) 296-3480 Outside the U.S.
THANK YOU!**

WARRANTY

Ultima II Filtration systems are warranted against failure due to defects in materials and/or workmanship during the warranty period. This warranty covers defects occurring under normal use and applies to the original purchaser at retail and may not be transferred. The warranty and remedies set forth herein are conditional upon proper storage, installation, use, maintenance and conformance with the applicable use. It will be based upon Aqua Ultraviolet's discretion as to whether the defects are of manufacturing origin. Any damages due to shipping and handling, packing, or installation are not covered by this warranty.

This warranty does not apply to appearance or accessory items. This warranty does not include damage due to handling, transportation, unpacking, set up, installation, repair or replacement of parts supplied by any other than Aqua Ultraviolet, improper maintenance, modification, or repairs by the purchaser, abuse, misuse, neglect, accident, fire, flood, or other acts of God.

Any oral statements about product made by the seller, the manufacturer, their representatives or any other parties do not constitute warranties and shall not be relied upon by the user and are not part of this contract.

Neither the seller nor the manufacturer shall be liable for any injury, loss or damages, direct, incidental or consequential including but not limited to incidental or consequential damage for lost profits, lost sales, injury, inability to use the product and the user agrees that no other remedy is available.

WARRANTY CONTINUED:

Before using, the user shall determine the suitability of the product for their intended use and the user shall assume all risk liability whatsoever in connection therewith.

To validate this warranty, mail the enclosed warranty card within 10 days of purchase along with proof of purchase (copy of sales receipt).

Warranty Period:

Complete Unit: One year from the date of purchase or 18 months from manufacturing date.

Limitations:

Warranty does not cover any malfunction from improper installation (we recommend that an authorized dealer or licensed plumber install your system to the specifications outlined in this owners guide).

Warranty only applies to the original end user and is not transferable.

Warranty does not cover repairs done by anyone other than Aqua Ultraviolet.

Warranty may not be modified by verbal statements by Aqua Ultraviolet, distributors, retailers, their agents or any other party.

Warranty covers the repair or prorated replacement of the Aqua Ultraviolet products. Aqua Ultraviolet denies all liability for any other loss including but not limited to loss of equipment, income, livestock or personal injury

Warranty is voided by the following:

Product labels defaced or removed.

Housing has been painted.

Product is improperly installed or maintained by user or agent.

Product abused, misused or damaged by user or their agent.

Product damage caused by failing to turn pump off when switching the handle setting.

Over tightening the valve.

Using any sealant other than Teflon tape on the valve.

Using any lubricant on o-ring under the valve.

Any implied warranty granted under state law including warranties of merchantability or fitness for a particular purpose are limited to one year from the date of purchase or 18 months from the date of manufacture or as otherwise stated in the above warranty. Aqua Ultraviolet is not responsible for direct, indirect, incidental or consequential damages. Some states do not allow limitations on how long an implied warranty lasts and/or does not allow the exclusions or limitations of incidental damages so the above limitation and exclusion may not apply to you. This warranty gives you special legal rights and you may also have other rights that vary from state to state.

Warranty Returns or Repair Returns:

Please call Aqua Ultraviolet at (800) 454-2725 for a "Return Merchandise Authorization" number (RMA). You must have a valid RMA from an Aqua Ultraviolet customer service representative before sending any product in for warranty or repair. Please have your serial number, date of purchase and product type available when calling for an RMA number.

All warranty returns or repair returns must come freight prepaid with an RMA number outside clearly marked on the box. All other returns will be refused. Aqua Ultraviolet will not be liable for any shipping cost to return warranty or repair items. Include a note in the box with your RMA number, name, address, daytime phone number and brief description of the reason for return or repair.

Be sure to return product in the same packing or similar packing and insure the package (we recommend sending it UPS). If you do not have or can't locate proper packaging, please call our customer service department and we will be more than happy to send you packaging for a minimal charge.

Aqua Ultraviolet shall not be responsible for damage or loss done by the shipper. Nor shall Aqua Ultraviolet be responsible for merchandise that arrives damaged due to improper packaging. All claims for loss and damage must be filed by the customer with the shipper.

If unit is found to be out of warranty we will contact you with the cost of repair. Your authorization is required prior to making any repairs.

INTRODUCTION

We at Aqua Ultraviolet would like to take the time to thank you for purchasing the finest filtration system on the market.

For over twenty years, Aqua Ultraviolet has manufactured filtration systems which are in use in many different fields and industries such as aquariums, aquaculture, public and commercial aquariums, educational institutions, government agencies, commercial and research organizations throughout the world.

Aqua Ultraviolet Ultima II Filters were created with our customers comfort in mind. Our patented backwash system takes just a few minutes a week and does not require draining a sludge valve or opening a filter. Within a few short weeks your filters bacterial bed will be fully established, and with our scientifically designed media you can be assured it will be well protected. So sit back and enjoy your pond again, courtesy of Aqua Ultraviolet.

HOW FILTRATION WORKS

Biological and mechanical filtration are essential to every pond, without it ammonia from the accumulated fish waste would harm your fish. The bacterial bed that builds on filter media will nitrify any ammonia in your pond making it a healthier environment for your aquatic life. Mechanical filtration picks up any debris in the pond, keeping your pond healthier and your fish happier.

HOW ULTIMA II BIO-MECHANICAL FILTRATION EXCELS

Bio-Mechanical filtration depends on the establishment of a colony of bacteria on the surface of the media that converts dissolved toxic nitrogenous waste to harmless compounds. When the bacteria are given the proper environment, they grow in a thin biofilm on the surface of each piece of media. The larger the surface area, the larger the bacterial colony. Our media surpasses the competition in this area with four to seven times the surface area of any other media available.

In order for the Ultima II filter to perform Bio-Mechanical Filtration the media must first establish itself enough to handle the load of dissolved ammonia presented to it. Depending on the temperature this can take 2-4 weeks for your filter to establish itself in your pond environment (this varies depending on climate, weather conditions, fish load and feed rates). Until the colony has grown large enough, the pond owner **MUST** be responsible for monitoring the levels of ammonia and nitrates in the pond water and take the appropriate measures to correct dangerously high levels.

CAUTION: READ ALL INSTRUCTIONS CAREFULLY BEFORE BEGINNING INSTALLATION OR OPERATION.

The following instructions should answer most of the questions that you may have about the installation, operation and use of your new Aqua Ultraviolet Ultima II Filter. If for some reason you should need technical support, we offer this service for free by telephone (800) 454-2725, or by fax (951) 296-3490 M-F 8:00 am - 4:30 pm Pacific Standard time except selected holidays or you may reach us through the web at www.aquaultraviolet.com.

SIZING CHART:

Item	Size	Max Pressure*	Pond Size (Gallons)
Ultima II Filter - 1000	12" Dia. x 22" Tall	38 PSI	1,000
Ultima II Filter - 2000	16 1/2" Dia. x 33" Tall	38 PSI	To 2,000
Ultima II Filter - 4000	20 1/2" Dia. x 35" Tall	38 PSI	To 4,000
Ultima II Filter - 6000	22 1/2" Dia. x 41" Tall	38 PSI	To 6,000
Ultima II Filter - 10000	24 1/2" Dia. x 42" Tall	38 PSI	To 10,000
Ultima II Filter - 20000	30 1/2" Dia. x 48" Tall	38 PSI	To 20,000
Ultima II Filter - 30000	37 1/2" Dia. x 54 1/2" Tall	38 PSI	To 30,000

Note: Optional 2" High Flow Top Valve available on 1,000 through 4,000 models

Note: 1-1/2" High Flow Top Valve comes standard on 1,000 through 4,000 models

Note: 2" High Flow Top Valve comes standard on 6,000 through 30,000 models

***CAUTION: DO NOT EXCEED MAXIMUM OPERATING PRESSURE OF 38PSI.**

FREQUENTLY ASKED QUESTIONS

Do I need to add any additional bacteria to my pond or my filter?

No, your Ultima II filter comes pre-seeded with natural bacteria to help the filter establish itself.

Do I need to add additional biological or mechanical filtration to my pond?

Not unless your pond has a lot of large debris (i.e. leaves, pine needles, string algae). If you have large debris in your pond a leaf basket or other pre-filtration system is recommended.

Can I bury my filter?

Yes, you can bury the filter up to the valve head. Please keep in mind that if you need to drain your filter for winter the drain valve will be buried and other means may be necessary to drain the filter.

How often do I have to Backwash?

It is recommended to backwash your filter once a week, however, depending on your fish load and feed rate it may be necessary to backwash more often, or less often. After a few weeks you will begin to notice how often it is necessary for your own pond.

How often do I have to replace the media?

Never, the media does not have to be replaced.

How often do I need to drain out the sludge?

Never, due to the exceptional backwashing system exclusive to our filters, all the waste is expelled through the waste line, and thoroughly cleans the filter eliminating the need for a sludge valve.

Can I medicate while the filter is running?

No, due to the non-specific nature of most medications on the market any medication designed to eliminate harmful bacteria in your pond would also destroy any beneficial bacteria inside your filter. If you need to medicate for any reason, you may set the valve to recirculate which will bypass the filter entirely and run through the valve only.

What is the maximum flow rate through my filter?

75 GPM on 1-1/2" Models and 125 GPM on 2" Models.

What size pump should I use?

Your pump will need to be an external direct drive pump that can pump the volume of your pond within one and a half hours at ten feet of head pressure.

What's the flow loss through the filter?

The filter flow loss ranges from 3-8ft of head, depending on how dirty the filter is.

Do I need to oversize my filter?

No, our filters were designed to handle heavy fish loads and heavy feed rates.

RECOMMENDED POND LAYOUTS

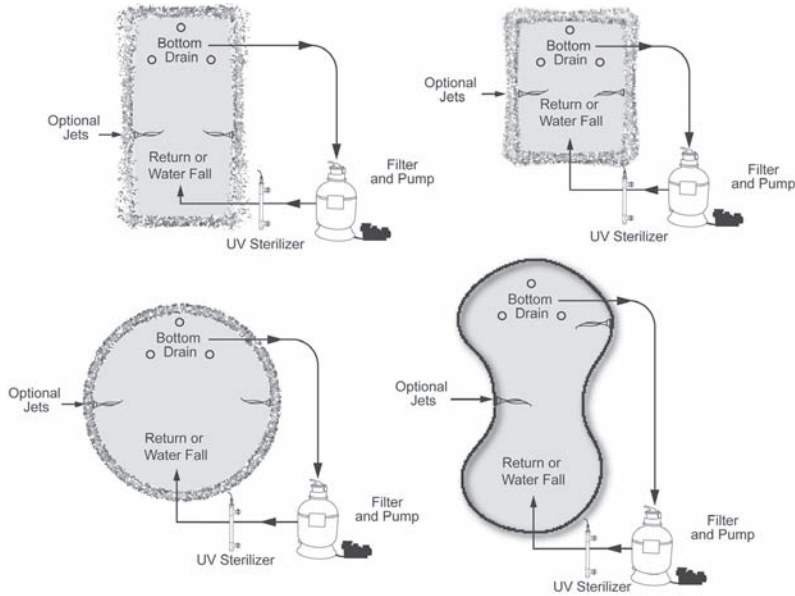

Incorrect Installation

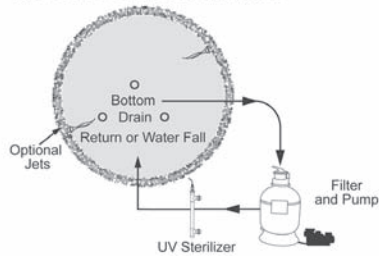

Incorrect Installation

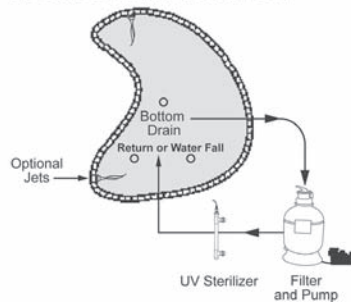

RECOMMENDED AQUARIUM LAYOUT

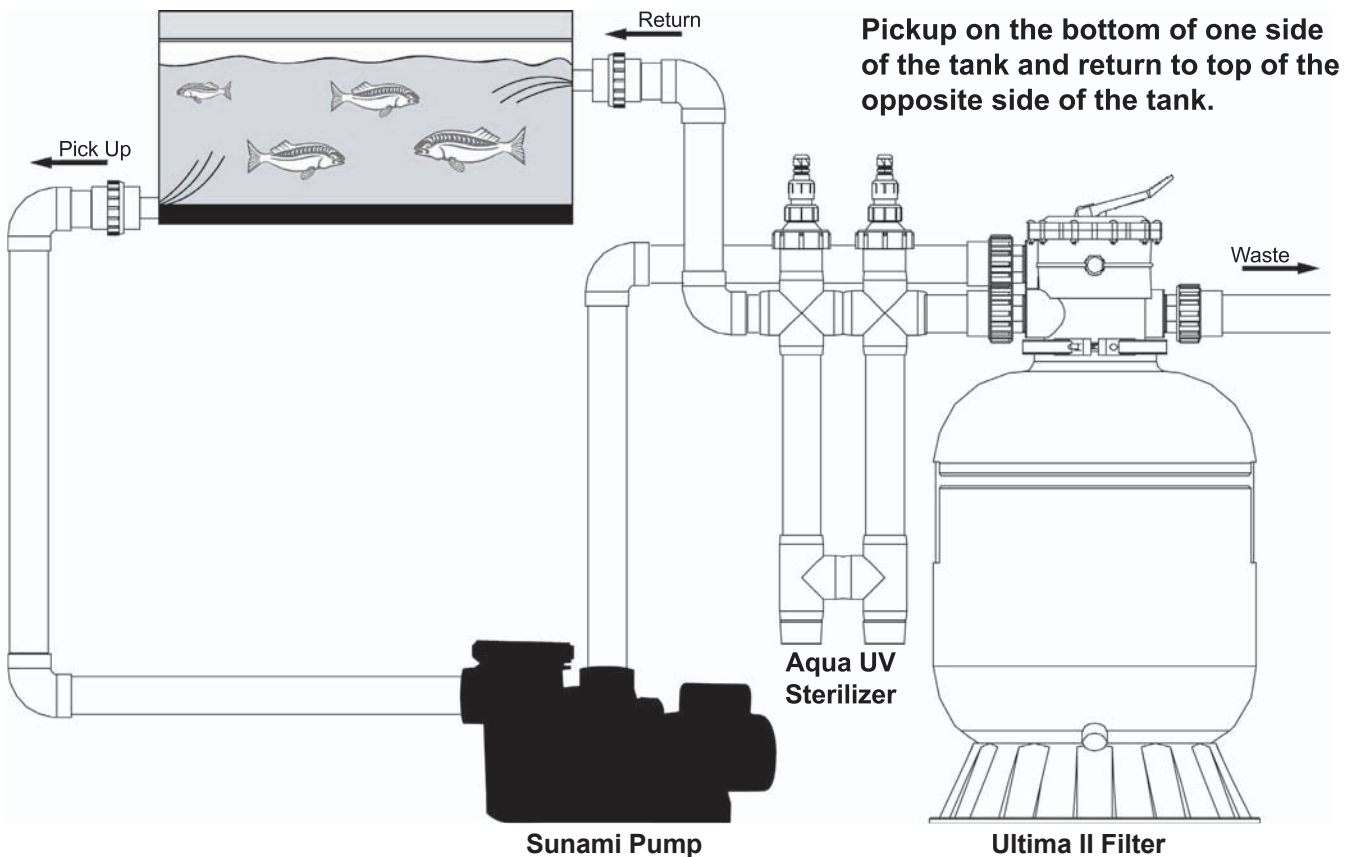

ULTIMA II INSTALLATION INSTRUCTIONS

CAUTION: The filter should be installed not more than 6 feet above pond water level, on a level surface, very firm ground, or equivalent, as recommended by your dealer. Position the filter so that the piping connections, and unions, control valve, and winter drain are convenient and accessible for operation, service and winterizing (if needed).

NOTE: For Ultima II 4000 models and up, pour the media inside the filter, which is loaded through the top opening of the filter.

NOTE: For 1000 and 2000 Filters skip to plumbing the filter, these filters come with media inside.

1. Installing The Media

- A. Cap internal standpipe with plastic cap to prevent media from entering it (See 1A).
NOTE: Do not pour media into standpipe or filter will fail under operation.
HINT: If you can not find the cap or cardboard for the install you can use a cup to cover the standpipe.

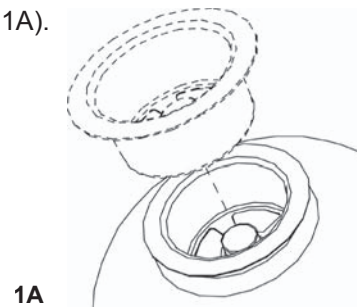

- B. Carefully pour in correct amount of media into filter, as supplied. (See 1B)
NOTE: Check to confirm that the standpipe is centered in the opening of the filter.

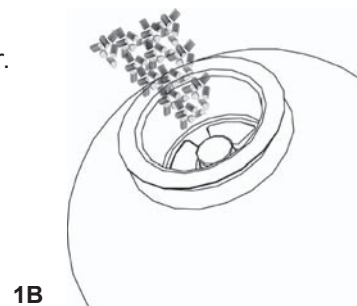

- C. Remove cap from stand pipe.

2. Assemble Valve to Filter

CAUTION: Do not lubricate any part of the Rim, Seals, or O-Ring

- A. Loosely pre-assemble both halves of the clamp with one screw and one nut, turning the nut 2 or 3 turns. (See 2A)

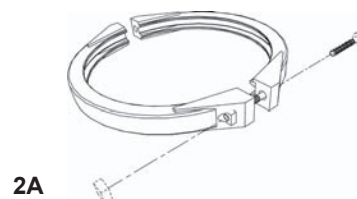

- B. Install clamp around tank and valve flange, and assemble second screw and nut. (See 2B)

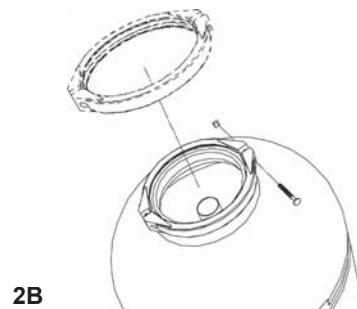

ULTIMA II INSTALLATION INSTRUCTIONS CONTINUED

C. Place valve O-ring around valve base. (See 2C)

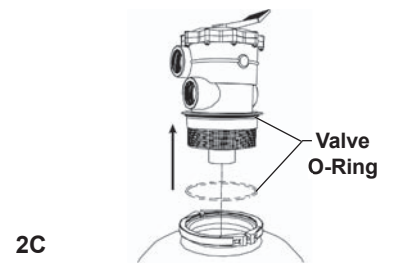

D. Insert Filter valve into the tank neck, taking care that the center pipe slips into the hole in the bottom of valve. Place clamp around valve flange and tank flange just enough so that the valve may be rotated on tank for final position. Final positioning to be done later. (See 2D)

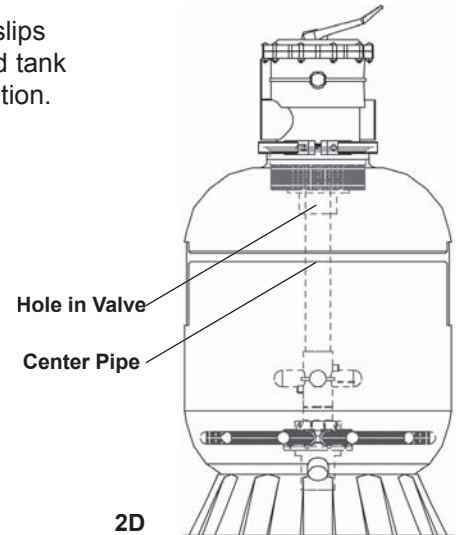

3. Plumbing the Filter

CAUTION: For 2" Valves only, Teflon tape has been applied to the unions for you. It may be necessary to apply more Teflon tape if the valve leaks upon installation. DO NOT attempt to use ANY sealant other than Teflon tape, as this can cause the valve to crack or leak immediately or over time. DO NOT over-tighten the unions. HAND TIGHTEN ONLY, DO NOT USE ANY TOOLS. Please be very careful during installation, valves where unions have been over-tightened and/or any sealant or putty of any kind has been used, will not be covered under warranty.

A. Attach unions to valve. (See 3A)

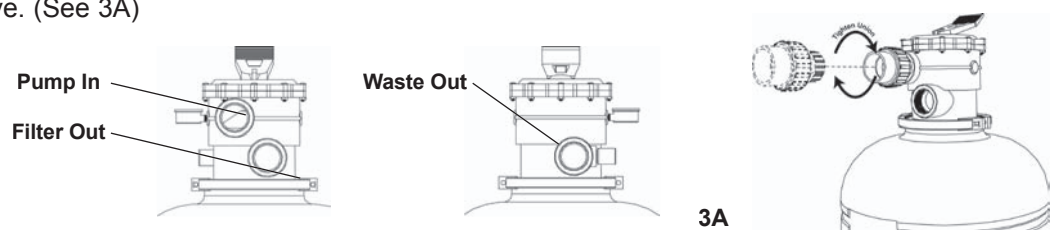

B. Once unions have been attached, glue pipe from pressure side of the pump to slip fitted side of union leading to valve port marked PUMP. (See 3B)

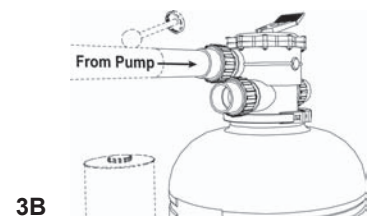

C. Glue return line to pond to slip fitted side of union leading to valve port marked RETURN. (See 3C)

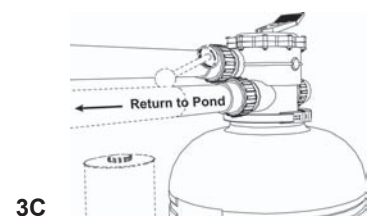

ULTIMA II INSTALLATION INSTRUCTIONS CONTINUED

D. Glue waste line from filter to slip fitted side of union leading to valve port marked WASTE. (See 3D)

NOTE: Do not decrease size of waste line.

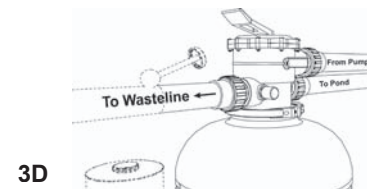

3D

E. Once valve is in final position and plumbing is set, tighten both sides of clamp alternately and evenly. Use a properly sized large screw driver and tighten firmly to obtain a good seal. (See 3E)

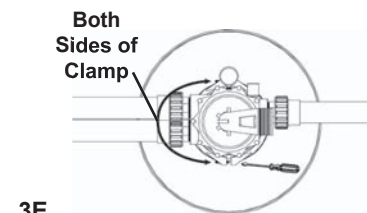

3E

F. Be sure to place vinyl protector caps over ends of screws. (See 3F)

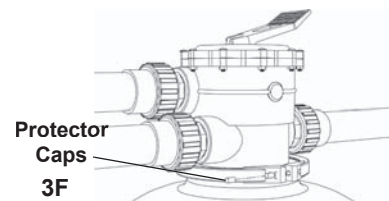

3F

4. Initial Startup of Filter

CAUTION: TO PREVENT DAMAGE TO CONTROL VALVE SEAL, ALWAYS TURN PUMP OFF BEFORE TURNING THE HANDLE.

A. Depress control valve handle and rotate to filter position. (See 4A)

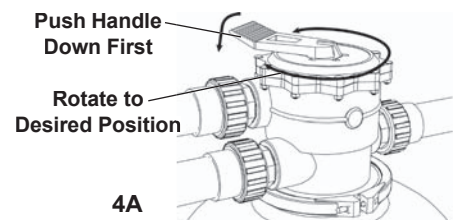

4A

B. Prime and start pump according to pump instructions. We recommend Aqua Ultraviolet Sunami pumps with all Ultima filters. (Or check with your dealer for alternative pump, should be high flow.)

C. Once water flow is steady, check for leaks.

NOTE: Please use appropriate pump for filter size (i.e. If your pond is 2000 gallons and you buy a 4000 gallon filter use 4000 gallon pump as well).

HINT: Note the initial pressure gauge reading when the filter is clean. (It will vary from pond to pond depending on pump and general piping system.)

NOTE: During initial clean up of pond water, it may be necessary to backwash frequently due to unusually heavy initial dirt load in the water. Do not install filter on a pond with heavy algae content (i.e. pea soup). We recommend a water change if the pond is really dirty.

VALVE SETTINGS

Setting	Description
Filter	For normal filtration of pond
Backwash	For reversing flow for cleaning filter, Operates jets
Rinse	For cleaning, plus resetting filter bed after backwashing
Waste	For lowering pond level/draining
Re-Circulate	For by-passing filter, but circulating water in pond
Closed	Shuts off flow from pump
Winter	For draining valve for winterizing. Leave on this setting throughout winter if not in use.

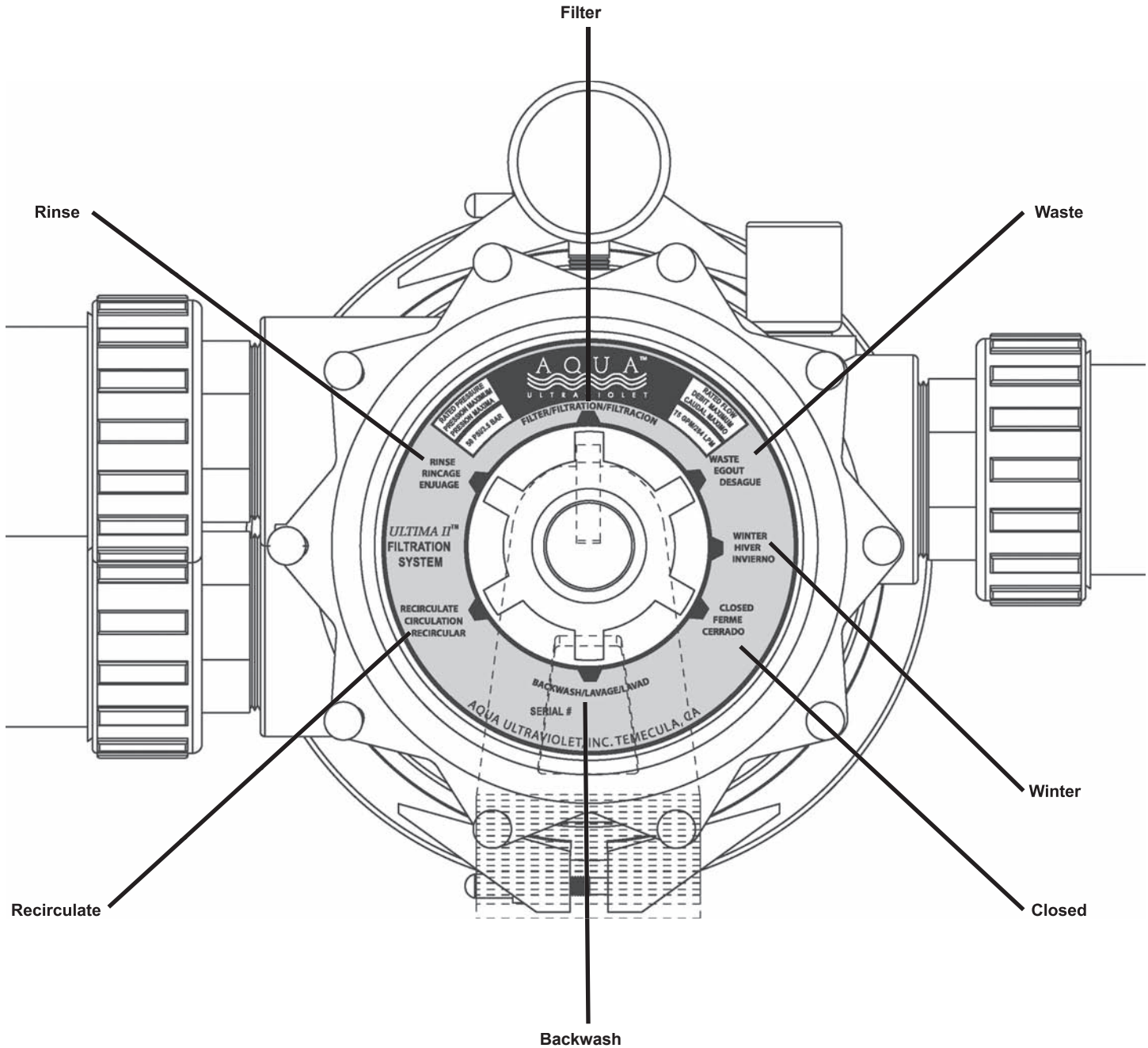

MAINTENANCE

Winterizing

1. Turn off pump
2. Completely drain tank by unscrewing drain cap at base of filter tank. Leave cap off during winter.

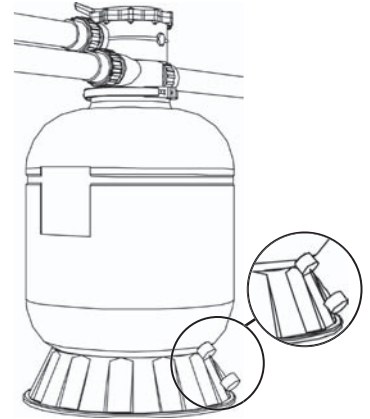

3. Depress valve handle and rotate so to set pointer on valve top between any two positions. This will allow the water to drain from the valve. Leave valve in this position.

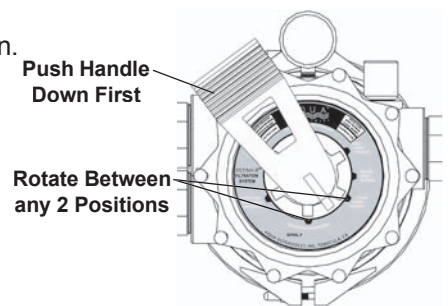

4. Startup after winter, install drain cap, take top off, stir up media, put top back on, put valve into backwash position, and turn pump on. Backwash then rinse.

PLEASE REALIZE...

Pure clean pond water is a combination of many factors, one is the proper Aqua Ultraviolet UV system, and another is adequate filtration and proper water flow. The higher flow rate through the pond turns the water more clear.

Now you can filter any pond, large or small and keep it crystal clear all year round without a huge expense.

If Your Filter Is Buried

1. Make sure pump is off
2. Take filter offline by disconnecting unions.

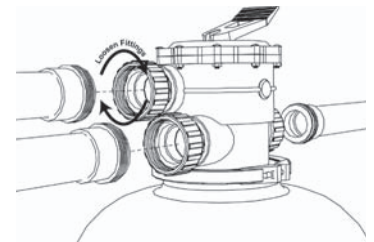

3. Loosen clamp screws and remove clamp.

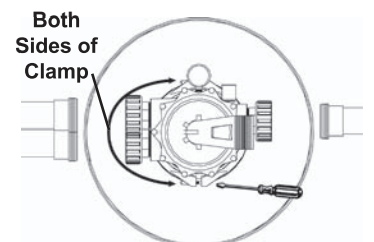

MAINTENANCE CONTINUED

4. Lift filter valve from body, you may need to loosen the valve by working it in a back and forth motion.

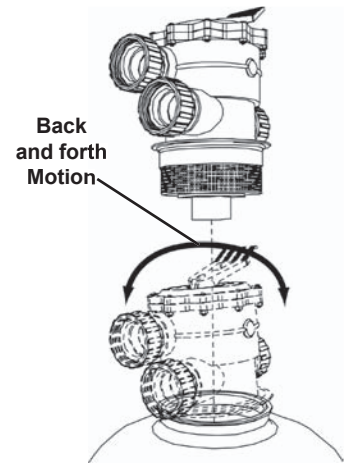

5. Use a Wet/Dry shop Vac with a strainer on the nozzle or submersible pump to remove the water from the filter. DO NOT REMOVE THE MEDIA.



6. Reattach the valve see page 8 for valve reassembly.

7. Depress valve handle and rotate so to set pointer on valve top between any two positions. This will allow the water to drain from the valve. Leave valve in this position.

Backwashing Your Filter

NOTE: Backwashing depends on how many times, how often you feed your fish and the time of the year. Before you begin backwashing check pressure gauge reading. We recommend cleaning once a week on light loads and twice a week or more on heavy loads. You must use some type of pre-filter or vortex for heavy waste (i.e. pine needles, large leaves, etc.).

1. Turn pump off.
2. Depress valve knob, rotate lever to backwash.
3. Turn pump on.
4. Backwash until sight glass is clear about 1/2 to 1 minute.
5. Turn pump off.
6. Depress knob and turn to rinse.
7. Turn pump on.
8. Rinse until sight glass is clear.
9. Repeat steps 1 through 8 twice for a total of 3 times.
10. Turn pump off.
11. Depress valve and turn back to filter.
12. Turn pump on and return to normal usage.

MAINTENANCE CONTINUED

How To Clean The Valve

NOTE: Occasionally the valve will need to be cleaned due to debris being lodged in various parts of the filter valve. The handle may become hard to turn or water may start leaking from the waste port.

If The Handle Is Hard To Turn

1. Power wash valve setting grooves located on the top portion of the valve.

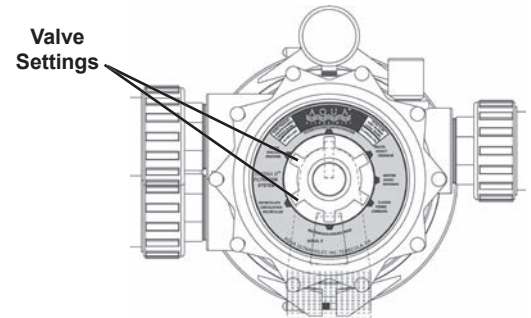

If Valve Is Leaking From The Waste Port

1. Turn pump off.
2. Place handle in between settings. (Do not place in a groove)

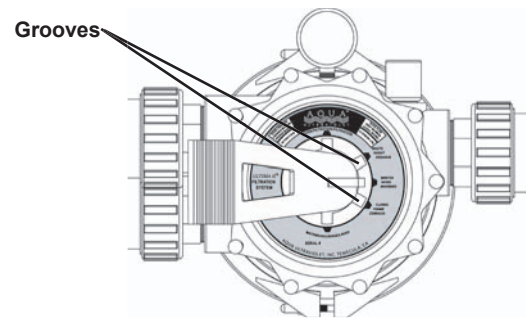

3. Turn pump on and run for a few minutes.
4. Turn pump off.
5. Switch handle to filter setting.

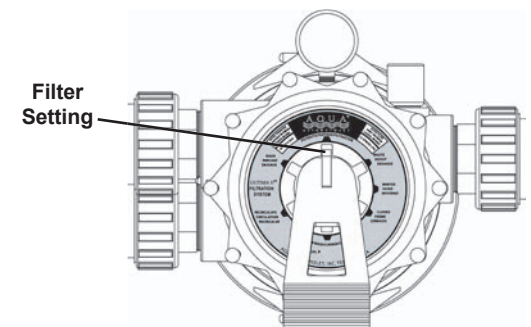

6. Turn pump on. Check if leak has stopped. (If leak continues go to step 7)

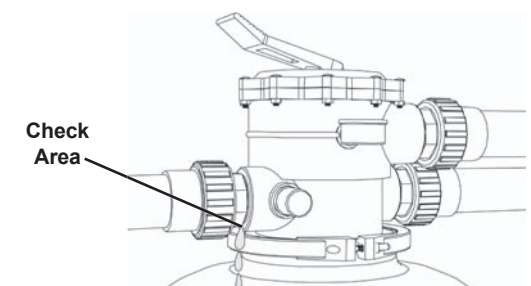

MAINTENANCE CONTINUED

How To Clean The Valve Continued

7. Turn pump off. Using a Phillips screwdriver and 7/16" wrench, remove the screws from the top of the valve.

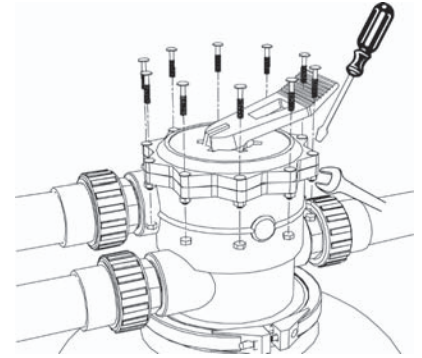

8. Remove cover from valve.

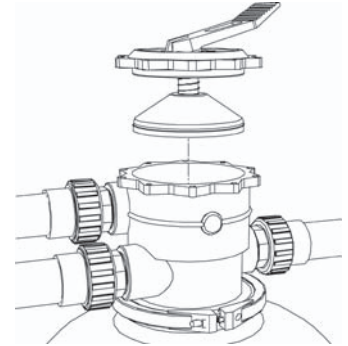

9. Rinse out inside of valve and check for any debris lodged under spider gasket or if spider gasket is out of place.

Spray Both Areas

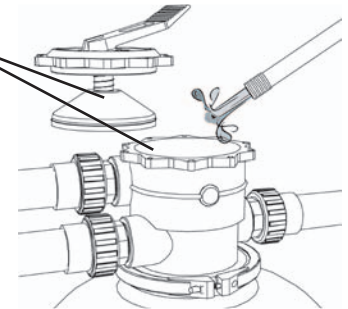

10. Re-attach top of valve.

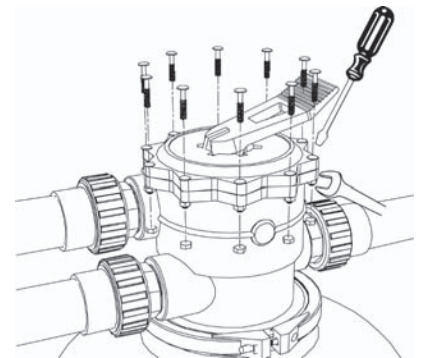

11. Turn pump on. Check if leak has stopped. (If leak continues call customer service for further assistance)

Check Area

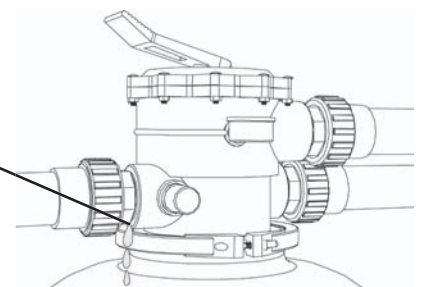

Troubleshooting Guide

Problem	Possibilities	Solution
My valve is leaking from the waste port.	<ul style="list-style-type: none"> • Handle was switched while pump was on • Debris lodged under spider gasket. (i.e. rocks, sand, etc.) 	See how to clean valve section on page 13
The flow out of the filter is considerably slower, and I have to backwash more frequently .	<ul style="list-style-type: none"> • Pump sized incorrectly • Pump is malfunctioning • Filter basket is clogged with large debris 	<ul style="list-style-type: none"> • Check pumps flow chart, make sure flow over 10ft of head can turn over pond in at least 1 1/2 hours • Check pump for any malfunctions • Check filter basket for large leaves, plant material, etc
My water is murky/brown	<ul style="list-style-type: none"> • Improper water circulation • Pump is malfunctioning 	<ul style="list-style-type: none"> • Check pump for malfunctions • Check circulation see page 6 for recommended pond layouts • Quartz sleeve in UV unit may need cleaning • UV lamp may need replacing (check manufacture's suggestion) • A UV unit may be necessary to achieve proper clarity
My valve handle is difficult to turn	<ul style="list-style-type: none"> • Pump is not turned off • Debris may be lodged in top valve assembly 	<ul style="list-style-type: none"> • Turn off pump before switching handle • Rinse off top portion of valve assembly • See section on how to clean valve on page 13
My water is still green	<ul style="list-style-type: none"> • No UV system or system improperly installed • Quartz sleeve is dirty • UV lamp needs replacing • Not filter related 	<ul style="list-style-type: none"> • If you do not have a UV unit we recommend purchasing one • Clean quartz sleeve per manufacture's suggestion • Check lamp life and replace if necessary
My valve is cracked at the ports	<ul style="list-style-type: none"> • A sealant instead of Teflon tape was used • Over-Tightened 	• Please call customer service at (800) 454-2725 for new valve purchase
My filter leaks from the clamp	<ul style="list-style-type: none"> • The valve is not seated correctly • The O-ring is pinched • The clamp is not tight enough 	<ul style="list-style-type: none"> • Re-seat the valve • Check O-ring • Check Clamp
My gauge doesn't register any pressure	<ul style="list-style-type: none"> • The filter is new • The pump is not sized correctly 	<ul style="list-style-type: none"> • Wait for the filter to establish • Buy a larger pump • Depending on pump, gauge may never register any pressure, Gauge should be used as a indicator only
There are small particles in my pond	<ul style="list-style-type: none"> • Circulation is bad • Pump picking up from skimmer 	<ul style="list-style-type: none"> • Make sure you are picking up and returning to opposite sides of the pond • Pick up water from bottom of pond
Media is coming out of my waste port	<ul style="list-style-type: none"> • The internal parts may be damaged • Media may be lodged in standpipe 	<ul style="list-style-type: none"> • Open filter and check for holes in laterals and basket • Please call customer service for further assistance

INCORRECT INSTALLATIONS

Incorrect Installation
Pump plumbed into return line

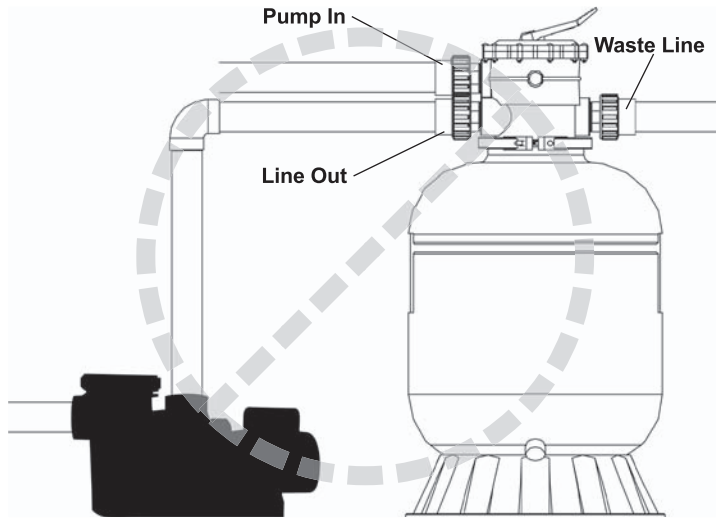

Incorrect Installation
Filter mounted more than 6' above pond level

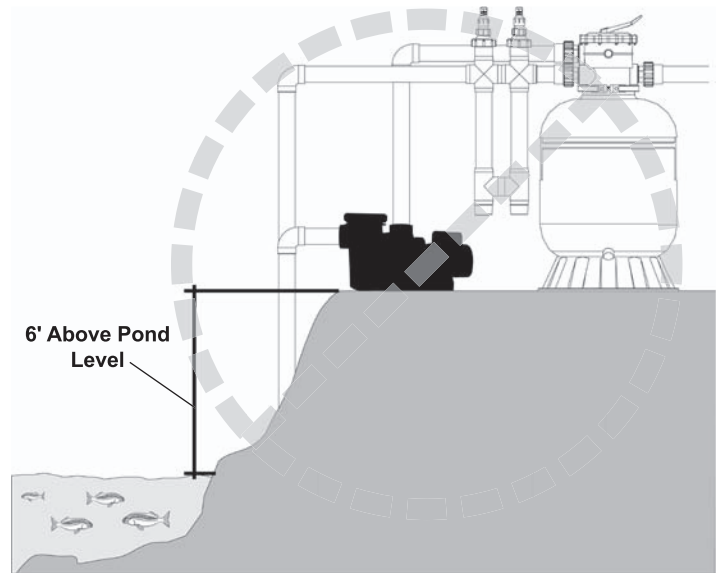

Incorrect Installation
Suction side of pump plumbed into filter

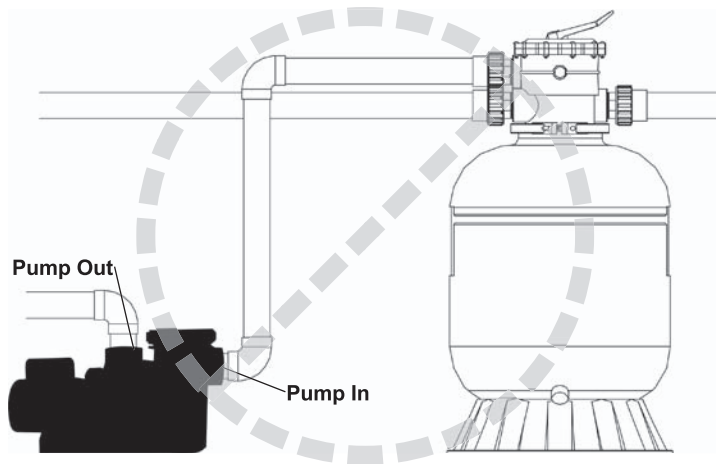

Correct Installation
Filter Mounted less than 3' away from pump into the right inlet and water coming from the correct outlet

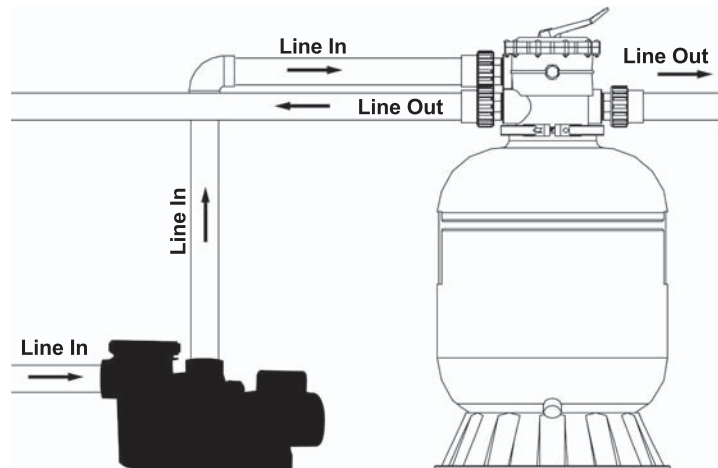

Incorrect Installation
Filter too far from pump

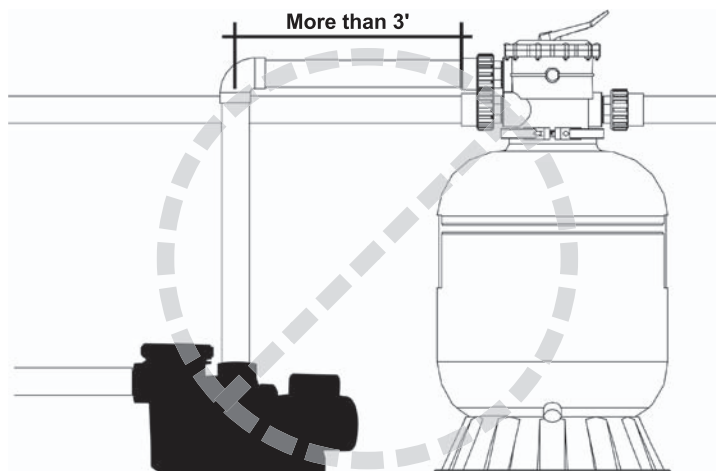

AQUA™

ULTRAVIOLET
